



ENTHALPY SERIES

Installation & Operation Instructions

A/ENT, A/DIFF-ENT, A/ENT-CTRL, A/ENT-CTRL-F1C

Phone: 1-888-967-5224

Website: workaci.com

GENERAL INFORMATION

The A/ENT-CTRL and A/DIFF-ENT are enthalpy controllers are used to monitor indoor and outdoor temperature and humidity before converting them into a relay output with the 24 VAC/VDC supply voltage sourced through the relay contacts when reaching its internal trip points. The supply voltage to the A/ENT-CTRL or A/DIFF-ENT is common to both the N/O or N/C contacts of the 10A Form C relay. The A/ENT-CTRL-F1C's version includes a dry contact closure or switch instead of sourcing the supply voltage through the relay contacts.

The A/ENT converts a capacitive type humidity sensor into a linear 2-wire, 4 to 20 mA loop powered output or it can be used in conjunction with the A/DIFF-ENT to determine whether your indoor or outdoor Enthalpy is greater. The A/ENT can be used with your Economizer control to monitor the indoor or outdoor Enthalpy over a range of 0 to 50 BTU's. Each unit in this series features a conformally coated circuit board and field selectable elevation adjustments.

MOUNTING INSTRUCTIONS

These units are not mounted in a NEMA 4 rated enclosure and should be mounted away from direct contact with the outdoor elements under an eave, shield, hood, or in a roof top unit. The PCB is conformally coated in order to protect the unit from contact with accidental moisture or humid air. The unit should be mounted using the two #8 x 3/4" self tapping TEK screws and inserting them through the holes in the integral mounting flange of the enclosure.

WIRING INSTRUCTIONS

ACI recommends the use of 18 to 22 AWG shielded cable for all wiring connections. All connections are to be made with a 1/4" female spade connectors (Amp Part# 2-520263-2 or equivalent). All wiring must comply with applicable local and national codes and ordinances. Be sure to make all connections with the power off.

FIGURE 1: DIMENSIONS
A/ENT-CTRL, A/ENT-CTRL-F1C

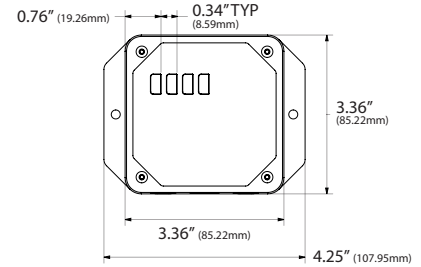

A/DIFF-ENT

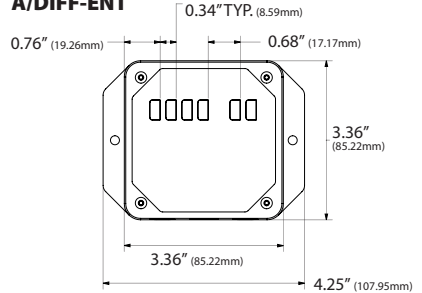

A/ENT

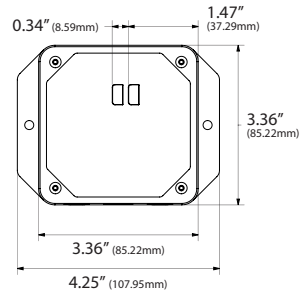

SIDE (ALL)

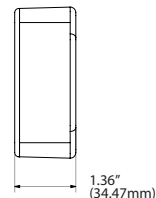

A/ENT

2-WIRE, 4-20 mA LOOP POWERED ENTHALPY TRANSMITTER (Theory of Operation).

The 2-Wire, loop powered enthalpy transmitter is designed to accept a +24 to 36 VDC supply voltage and output an equivalent 4-20 mA output signal equal to a range of 0 to 50 BTU's. See **Figure 2** for a detailed wiring diagram.

Note: The enthalpy calculation is being done using an average altitude of 1000 FT above sea level.

FIGURE 2: A/ENT WIRING

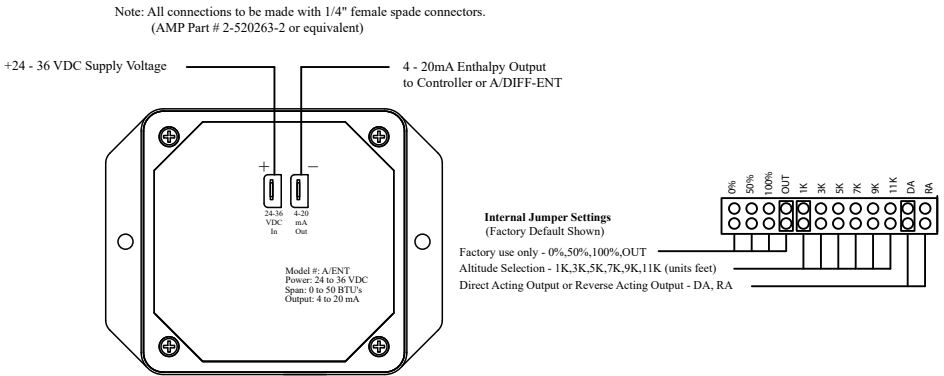

A/ENT-CTRL, A/ENT-CTRL-F1C (Enthalpy Controller)

The outdoor enthalpy controller is designed to accept industry standard 24 VAC (or DC) supply voltage to power the unit. The unit will measure both the temperature and relative humidity, and compensating for altitude, calculate the overall enthalpy of the outdoor air. The enthalpy controller switch is designed with four switch selectable trip points. Each trip point has a hysteresis or dead band of approximately 1 BTU and 0.5°F.

A/ENT-CTRL: The unit will provide a 10A Form 1C, SPDT relay contact with a 24 V supply voltage being sourced from the 24 VAC input transformer to the end device or unit. The "Relay Common" is referenced to the 24 VAC terminal of the 24 VAC transformer.

A/ENT-CTRL-F1C: The unit will provide a 10A Form 1C, SPDT Dry contact closure. The "Relay Common" is referenced to the GND terminal of the 24 VAC transformer.

The relay will be "Energized" or in the normally-open (N/O) position when the outdoor air enthalpy and temperature is equal to or greater than the enthalpy and temperature trip points specified in Table 1. The relay will then "De-Energize" or be in the normally-closed (N/C) position when the outdoor air enthalpy and temperature are both less than their hysteresis or dead band values. See **Figure 3 and 4 (p.3)** for a detailed wiring diagram for the A/ENT-CTRL and A/ENT-CTRL-F1C.

Note: The enthalpy calculation is being done using an average altitude of 1000 FT above sea level.

FIGURE 3: A/ENT-CTRL

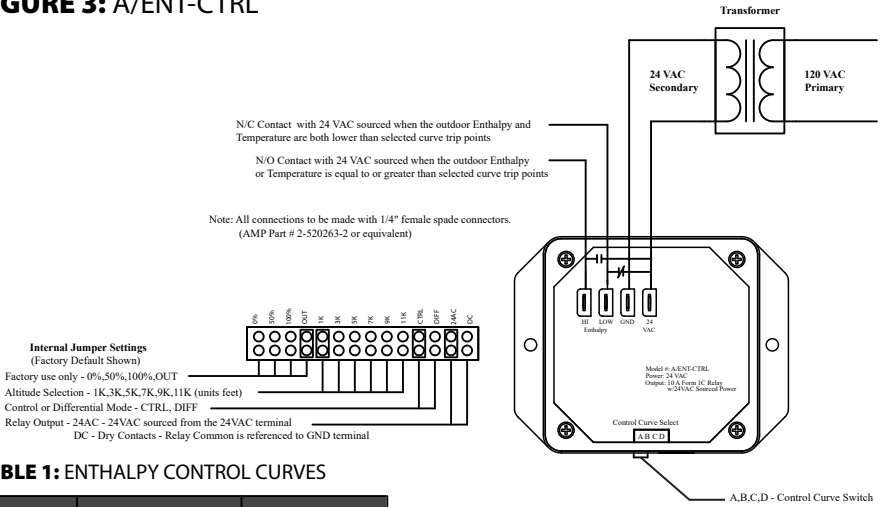

TABLE 1: ENTHALPY CONTROL CURVES

Curve Set Points	Enthalpy Set Point (BTU's)	Temp Set Point (°F)
A	28	75
B	24	70
C	23	67
D	21.5	63

FIGURE 4: A/ENT-CTRL-F1C

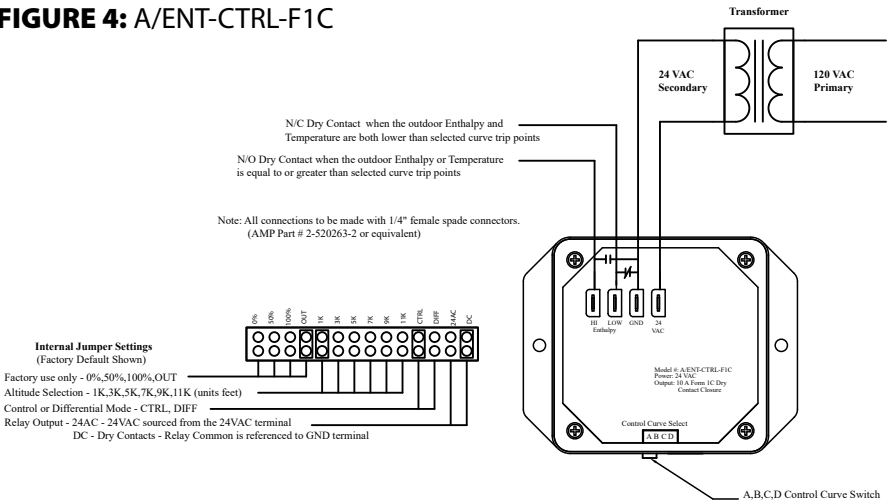
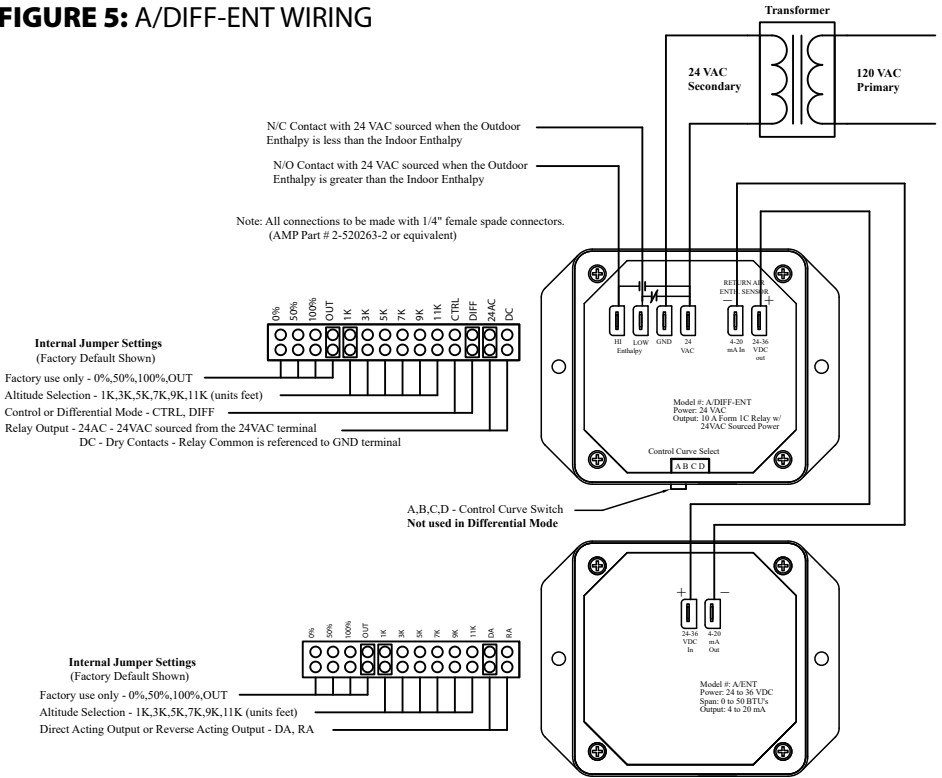

FIGURE 5: A/DIFF-ENT WIRING



A/DIFF-ENT

The Differential Enthalpy control is identical to an enthalpy controller, except the switch decision is based on a comparison with local air via a loop transmitted sensor. Typically the differential enthalpy will measure the outdoor temperature and relative humidity and, compensating for altitude, calculate the overall enthalpy of the outdoor air. The indoor enthalpy is then measured using the 2-wire, 4 to 20 mA loop powered enthalpy transmitter. A 24 VDC supply voltage is sent to the enthalpy transmitter through the Vout terminal. The return has a 4-20 mA signal being sent back to the 4-20 mA input terminal of the differential enthalpy unit. There is a hysteresis or dead band of approximately 1 BTU and 0.5°F between the two units. When the outdoor enthalpy is less than the indoor enthalpy, the differential enthalpy unit will output the 24 supply voltage from the N/C contact of the 10A Form 1C relay. If the outdoor enthalpy is greater than the indoor enthalpy, the differential enthalpy unit will “Energize” the relay and output the 24 supply voltage from the N/O contact of the 10A Form 1C relay. The “Relay Common” is referenced to the GND terminal of the 24 V input. See **Figure 5** for a detailed wiring diagram for the A/DIFF-ENT.

Note: The enthalpy calculation is being done using an average altitude of 1000 FT above sea level.



PRODUCT SPECIFICATIONS

NON-SPECIFIC INFORMATION	
Supply Voltage:	+24 to 36 VDC or 24 VAC +/- 10% (A/ENT-CTRL & A/DIFF-ENT) +24 to 36 VDC (A/ENT)
Supply Current:	70 mA max (A/ENT-CTRL & A/DIFF-ENT), 25 mA maximum (A/ENT)
External Input (A/DIFF-ENT Only):	4-20 mA (0 to 50 BTU's) from A/ENT
Enthalpy Measurement:	0-50 BTU's (A/ENT)
RangeOutput/Contact Rating:	4-20 mA (A/ENT) 10A @ 250 VAC (A/ENT-CTRL & A/DIFF-ENT)
Relay Deadband:	1 BTU or 0.5°F (0.27°C)
Enthalpy Accuracy:	+/- 1 BTU @77°F (25°C)
Long-term Stability:	Less than 2% RH Drift/5 years
Sensitivity:	0.1% RH
Repeatability:	0.5% RH
Operating RH Range:	0 to 95% RH (non-condensing)
Operating Temperature Range:	-40°F to 140°F (-40°C to 60°C)
Standard Elevation:	1000' above sea level (standard)

WARRANTY

The ACI Enthalpy Series temperature sensors are covered by ACI's Five (5) Year Limited Warranty, which is located in the front of ACI'S SENSORS & TRANSMITTERS CATALOG or can be found on ACI's website: www.workaci.com.



NOTES

NOTES



NOTES

NOTES



